

# Design, Simulation, and Microfabrication of a Heat-Conduction DNA Chip with Integrated Microheaters

Shifeng Li and Shaochen Chen, Dept. of Mechanical Engineering,  
The University of Texas at Austin, Austin, Texas, USA. *E-mail:* scchen@mail.utexas.edu

## Abstract

A continuous-flow polymerase chain reaction (PCR) system with integrated heaters for DNA amplification has been designed and fabricated. A new concept of obtaining a temperature zone by natural heat conduction is presented. The finite element method is employed to analyze the temperature distribution in the DNA chip. The system is integrated through a microfluidic interconnect based on polydimethylsiloxane (PDMS) material. Using oxygen RIE bonding, the PDMS interconnect can withstand a pressure up to 470 kPa. The fabrication process for the DNA chip is developed using micromachining techniques. The temperature distribution was measured. The uniformity of the denaturation temperature, annealing temperature, and extension temperature was 1.5°C/mm, 0.7°C/mm, and 3.1°C/mm, respectively. The microchannel has a width of 380 μm, a depth of 30 μm, and a total length of approximately 0.6 m. Depending on the flow rate (5 nL/s to 80 nL/s), the 20-cycle DNA chip needs only 52 seconds to 14 minutes for thermal cycling.

**Keywords:** Heat Conduction, PCR, Microfabrication, Microfluidics, Interconnect, PDMS

## Introduction

A polymerase chain reaction (PCR) is a technique used to amplify a specific gene or region of DNA. PCR applications range from diagnosis of infectious diseases to analysis of specific gene mutations that occur in a variety of genetic disorders. Since its development, PCR has become one of the most useful and versatile methodologies applied to molecular biological applications. The current state-of-the-art PCR protocol is labor intensive in setup and requires several hours of time as well as large sample volumes (25 to 50 μL). The protocol is error prone on several technical levels, and results can be muddled by exogenous DNA contamination (Mullis, Ferre, and Gibbs 1994).

Recently, microfabrication technology has led to the development of a variety of miniature PCR devices. There are two types of micro PCR devices. One is a stationary chamber type by cycling the temperature in the chamber (Northup et al. 1998). The reaction chamber is usually fabricated by anisotropic etching of a silicon substrate. The thermal cycling is performed by an on-chip polysilicon microheater. The other type of micro PCR device is based on continuous flow, where the sample flows through three well-defined temperature zones (Kopp, de Mello, and Manz 1998). This micromachined “chemical amplifier” relies on the movement of PCR reaction samples through microchannels (40 μm deep and 90 μm wide) across defined temperature zones on a glass microchip. Using 20 cycles of PCR amplification, a 176-base pair fragment from the gyrase gene of *Neisseria gonorrhoeae* was successfully amplified at various flow rates, resulting in total reaction times of between 90 seconds and 18.7 minutes. However, this device requires extra elements for heating and cooling as well as for controlling the reaction temperatures.

The thermal cycling in a PCR device involves three temperatures: 90°C to 95°C for DNA denaturation, 50°C to 65°C for DNA hybridization, and 70°C to 77°C for DNA replication. The first step in PCR is to separate the two template strands at the denaturation temperature. The second step is binding of the specific primers to their target strands at hybridization temperature. The third step is to extend the primers with the heat-stable DNA polymerase enzyme, using the DNA strand as a template at the replication temperature. The cycle is then repeated until enough amount of the DNA sample is obtained (usually 20 to 40 cycles). The way in which the three specific

temperatures are implemented is very important for device performance. Kopp, de Mello, and Manz (1998) used three copper blocks to provide three temperature zones. This method requires the attachment of the copper blocks to the glass wafer and enough space between heaters to avoid lateral heat conduction among heaters, which would result in thermal cross-talk between three temperature zones. A silicon thermal cycler was invented to create three specific temperatures using three different heaters on a silicon substrate (Schneegab and Kohler 2001). As reported, this approach requires a longer cycling time because of larger space between three temperature zones due to silicon's high thermal conductivity. We presented a batch-fabricated, continuous-flow PCR using microelectromechanical systems (MEMS) techniques (Zheng and Chen 2001, 2002). Three microheaters were integrated onto a glass chip for thermal cycling, aiming to reduce the cost and make the device compact.

In this work, a new concept of obtaining temperature zones is presented. The temperature zone (72°C) for replication is not created by direct microheater heating, but by lateral heat conduction from heaters for denaturation (95°C) and hybridization (55°C). Soda-lime glass was chosen for the substrate material because it is biocompatible with DNA molecules and is transparent, which facilitates optical detection. The finite element method (FEM) was employed to analyze the temperature distribution in the DNA chip. Three designs are compared: one heater, two heater, and three heater. To connect the microfluidic system to its macro environment, microfluidic interconnects made of polydimethylsiloxane (PDMS) material were developed and tested.

## Design and Simulation

### Microheater System Design

For DNA amplification, it is necessary to cycle the reaction mixture through three temperatures (e.g., denaturation temperature 90°C – 95°C, hybridization temperature 50°C – 65°C, and replication temperature 70°C – 77°C) multiple times. This could be realized by using three independent thin-film heating elements integrated onto the surface of the glass wafer, as illustrated in *Figure 1*. When the DNA sample flows through the microchannel across the PCR chip, it will experience three distinct temperatures. Just like a stationary PCR using continuous

thermal cycling, the continuous-flow PCR follows the sequence of “denaturation-hybridization-replication” at designed temperatures for successful DNA amplification (Kopp, de Mello, and Manz 1998; Sun et al. 2002; Zhang et al. 2002). Because the flow rate is constant across the microchannel, the amount of time in which the reaction sample is exposed to each temperature zone is adjusted by varying the pattern of the microchannel. The time of thermal cycling is controlled by the number of cycles of the microchannel crossing the three temperature regions.

To obtain the three temperature zones for DNA denaturation, hybridization, and replication, three different designs were considered: (1) three heater, (2) one heater, and (3) two heater. In the three-heater design, three temperatures are obtained independently by each heater. However, this configuration would be very complicated because it needs three heating systems and there is possible cross-talk between microheaters. Previously, this cross-talk problem was solved by blowing cold air between the microheaters using fans located outside the chip (Obeid et al. 2003). In the one-heater design, the microheater is used to establish the denaturation temperature (95°C), while the hybridization and replication temperatures will be obtained by the lateral heat conduction along the chip substrate. This is a very simple design. However, a problem may arise with temperature nonuniformity in both the hybridization and replication zones due to fast temperature drop along the direction of heat conduction. In the two-heater design, two heaters are employed to form two uniform temperature zones for denaturation and replication, while the hybridization temperature is obtained by lateral heat conduction in the glass substrate from the heaters for denaturation and replication (*Figure 1*).

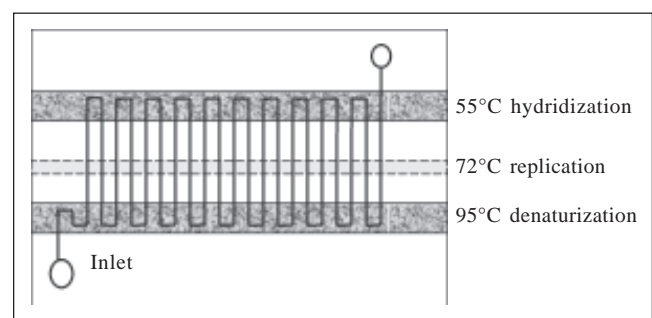

*Figure 1*  
Schematic of Continuous-flow PCR Device

## Material Selection

Traditional stationary PCR devices are often made of silicon material because of its good thermal conductivity and mature fabrication techniques (Northup et al. 1998). However, silicon is not biocompatible and has been shown to reduce the DNA amplification efficiency (Schneegab and Kohler 2001). For these reasons, glass is often chosen as the substrate material because it is biocompatible and transparent for optical detection (Kopp, de Mello, and Manz 1998; Zheng and Chen 2001, 2002; Obeid et al. 2003). Additionally, glass has 10 times the thermal resistance of silicon. A larger thermal resistance helps to implement well-defined temperature zones. Based on these considerations, soda-lime glass was chosen for the substrate material.

## FEM Simulation

To verify these different designs, finite element analysis was conducted to investigate the temperature distribution in the PCR device. The heat convection inside the microchannel was neglected due to the fluid flow across the heaters because the thermal mass ratio of the DNA solution to the glass substrate is less than 1:100 (Kopp, de Mello, and Manz 1998). Ansys 5.6 was used in this work for thermal analysis. A 2-D model was built with solid 55 with a total of 1000 mesh elements. Material properties used in the simulation are listed in *Table 1*. The simulation results for the temperature distribution along the glass chip are shown in *Figure 2*. Apparently, the three-heater design offers good uniformity in the three temperature zones; however, to avoid cross-talking, a much larger space must be reserved between heaters. This not only increases the cycling time but also increases the flow resistance due to a longer channel length. For the one-heater design, there is only one heater to establish the denaturation zone of 95°C. Due to lateral heat conduction, the temperature reduces gradually along the length of the device. Based on the FEM analysis, it is possible to set up the hybridization and replication zones at

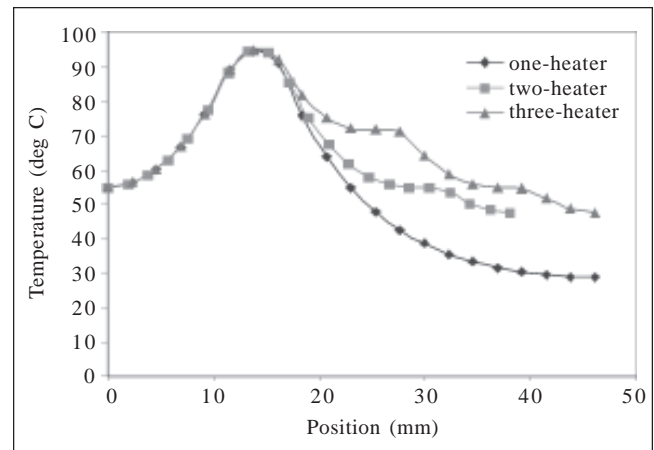

**Figure 2**  
 Comparison of Temperature Distribution Along the PCR Chip for Three Different Heater Designs

certain locations along the direction of lateral heat conduction without using a heater. The PCR device based on the one-heater design was easy to fabricate, but FEM simulation showed that the temperature gradient was approximately 6°C/mm in the replication zone. To prevent this “rapid” temperature gradient problem, it is proposed to use the two-heater design. Because the temperature and cycling time for denaturation (95°C) and hybridization (55°C) are critical to the DNA amplification efficiency (Campbell 1995), two heaters are placed on both ends with one heater for the 95°C zone and the other for the 55°C zone. Due to lateral heat conduction, the replication zone (typically  $72 \pm 2^\circ\text{C}$ ) is established between the two heaters with a reasonable uniformity (less than 3°C/mm), as shown in *Figure 2*. This will lead to a width of larger than 1 mm for the replication zone. For the designed flow rates, this length is long enough for successful replication as demonstrated before (Kopp, de Mello, and Manz 1998; Lin et al. 2000a).

In addition to temperature distribution control, the thermal entry length was also analyzed for each temperature zone at flow rates ranging from 5 nL/s to 80 nL/s. When the DNA solution goes through the

**Table 1**  
 Material Properties for Temperature Distribution Analysis and Thermal Entry Length Analysis

	Specific Heat (J/kgK)	Thermal Conductivity (W/mK)	Density (kg/m <sup>3</sup> )	Viscosity (kg/ms)	Convection Heat Transfer Coefficient (W/m <sup>2</sup> K)
Soda-lime glass	753	1.1	2400		7.5 (with the air)
DNA sample	4182	0.643	1000	0.0005	

three temperature zones, it needs time to ramp up or cool down to reach the required denaturation, hybridization, and replication temperatures. Thus, information about the thermal entry length is important for heater design. Again, Ansys 5.6 was used to build a two-dimensional finite element model. As listed in *Table 1*, the thermal properties of water were used for the DNA sample (Lin et al. 2000a, 2000b). *Figure 3* shows the temperature profile for different temperatures and flow rates. For all cases, the thermal entry length is less than 100  $\mu\text{m}$ , indicating that the temperature ramping up time for the DNA solution is less than 0.01 s. This rapid thermal ramping rate is due to fast heat diffusion in a microscale dimension. For the designed 4 mm width of the microheaters, the DNA solution has enough time to be held at the denaturation and hybridization zones for chemical reaction.

## DNA Chip Fabrication and System Integration

### DNA Chip Fabrication

A schematic diagram of the fabrication process is shown in *Figure 4*. The polished soda-lime glass wafers were cleaned with a Piranha solution ( $\text{H}_2\text{O}_2$  :  $\text{H}_2\text{SO}_4$  = 825 mL : 1650 mL) for 8 minutes, then rinsed with DI water and dried with  $\text{N}_2$  gas. The dehydration process was carried out by baking the glass wafer on a hot plate at  $100^\circ\text{C}$  for 3 minutes to remove the residual water molecules. The glass wafer was then coated with hexamethyldisilazane (HMDS). The primer-treated glass wafer was baked on a hot plate at  $100^\circ\text{C}$  for 3 minutes to enhance photoresist adhesion, and then was spin-coated at 2000 rpm for 30 seconds with AZ 4620 photoresist. The photoresist thickness is approximately 10  $\mu\text{m}$ . After photoresist coating, the glass wafer was soft-baked at  $90^\circ\text{C}$  for 30 minutes to remove the solvent in the photoresist. Before putting the wafer on the aligner, the glass wafer rested for 5 minutes to cool down. The coated glass wafer was then exposed for 2 minutes and dipped into AZ726 developer for 2 minutes. After rinsing by DI water and drying by  $\text{N}_2$  gas, the patterned glass wafer was hard-baked in three steps: (1) bake at  $90^\circ\text{C}$  for 10 minutes, (2) ramp to  $120^\circ\text{C}$  and hold for 10 minutes, and (3) ramp down to room temperature at  $1^\circ\text{C}/\text{min}$ . The three-step hard-baking processes has been proven to be necessary and use-

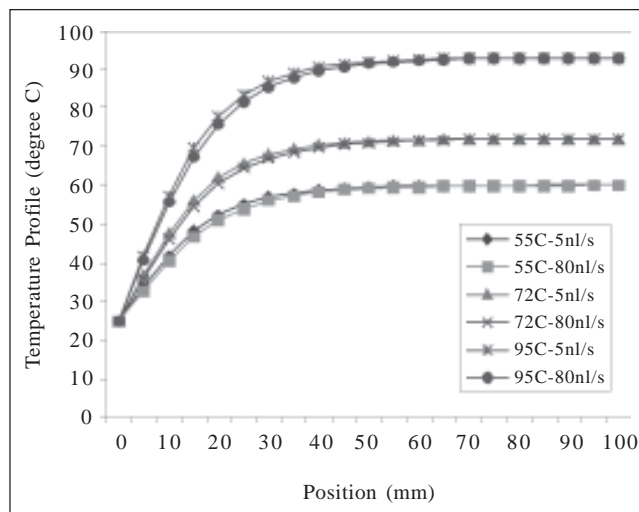

*Figure 3*  
Simulation Results of the Thermal Entry Length  
for Different Temperatures and Flow Rates

ful to release accumulated thermal stress inside the photoresist and to enhance adhesion between the photoresist soft mask on the glass wafer. After hard-baking, the glass wafer was put into a diluted HF solution ( $\text{HF}$  :  $\text{HNO}_3$  :  $\text{H}_2\text{O}$  :  $\text{HCl}$  = 200 mL : 100 mL : 1600 mL : 400 mL). A magnetic bar was used to stir the solution to remove reaction residues on the glass surface. With an etching rate of 2–3  $\mu\text{m}/\text{min}$ ., a microchannel 30–40  $\mu\text{m}$  in depth was produced after 15 minutes of HF etching. *Figure 5* shows SEM micrographs of the etched microchannel on the glass substrate.

On another glass wafer, two through-holes with a diameter of 1.0 mm were drilled using an abrasive tip coated with artificial diamond. These two holes were used as the inlet and outlet for the DNA sample. Finally, the glass wafer with two through-holes and the glass wafer with the microchannel were bonded together by thermal fusion bonding (Lin et al. 2001). After bonding, the heaters were deposited onto the bottom side with 100 nm Ti and 80 nm Au with lift-off techniques.

### PDMS-Based Interconnects

Interconnecting is an important part of integrated micro total-analysis systems. A PDMS-based interconnect has been developed for the PCR chip in this work.

First, a curing agent and a PDMS prepolymer (SYLGARD 184 Silicone Elastomer Kit, Dow Corning, Midland, MI) in a 1:10 weight ratio was thor-

oughly mixed. Then, the prepolymer mixture was degassed for one hour in a 20–25 mmHg vacuum chamber to remove air bubbles from the mixture and to ensure complete mixing of the two components. The prepolymer mixture was then poured onto the silicon wafer and covered carefully with a transparent film to prevent any bubble formation at the interface. After curing the entire stack for 1 hour at 145°C on a hot plate, the PDMS layer was peeled off from the silicon wafer. The thickness of the PDMS film was approximately 1–2 mm. The PDMS layer was cut into 4 mm × 4 mm squares with a blade, and a glass capillary (O.D. 0.84 mm and I.D. 0.60 mm, Vitrocom, Inc, NY) was used to punch connecting holes in the PDMS squares, as shown in *Figure 6*. The substrate and PDMS interconnects were then cleaned and bonded using RIE oxygen bonding. An optical micrograph of the PDMS interconnects integrated onto the PCR chip is shown in *Figure 7*.

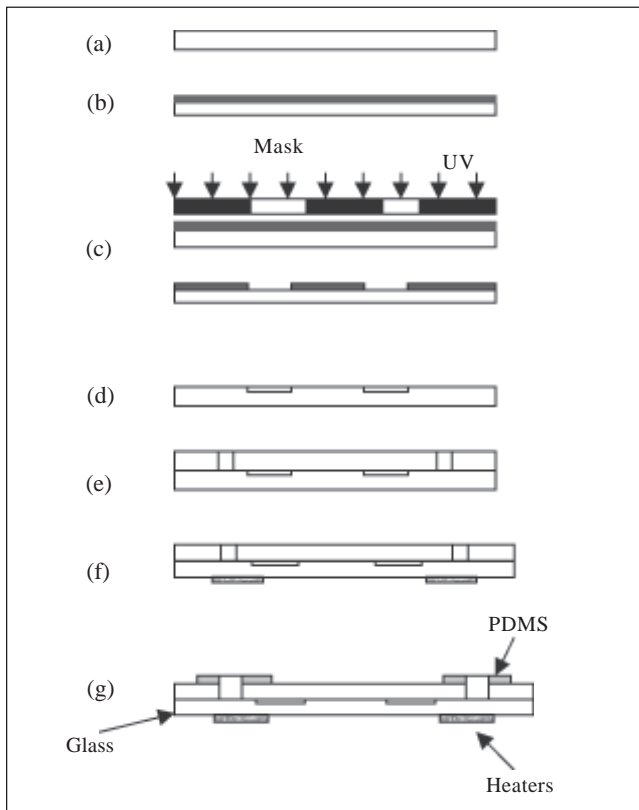

*Figure 4*

**Schematic Representation of Fabrication Process for the DNA Chip:** (a) glass wafer cleaning in Piranha solution, (b) spin coating of the photoresist, (c) photolithography, (d) HF wet etching, (e) through-hole drilling of the top glass wafer and thermal fusion bonding, (f) lift-off process to deposit microheaters (100 nm Ti and 80 nm Au), (g) PDMS interconnect bonding using RIE

The PDMS interconnectors are characterized using a leakage pressure test. The leakage pressure, defined as the maximum working pressure that the PDMS interconnect can stand, was measured by connecting a syringe to the PDMS interconnector. A three-way pressure gauge tee (Upchurch U.433, Upchurch Scientifics) connecting a pressure gauge (Model 1202-5000, Cole-Parmer Instrument Co.) to the syringe was used to measure the leakage pressure. The PDMS interconnect was bonded to the glass substrate by O<sub>2</sub> RIE bonding. The test results showed that the PDMS interconnect could stand a pressure up to 470 kPa.

## Results and Discussion

### Temperature Measurement

The temperature distribution of the device is important for polymerase chain reaction inside the

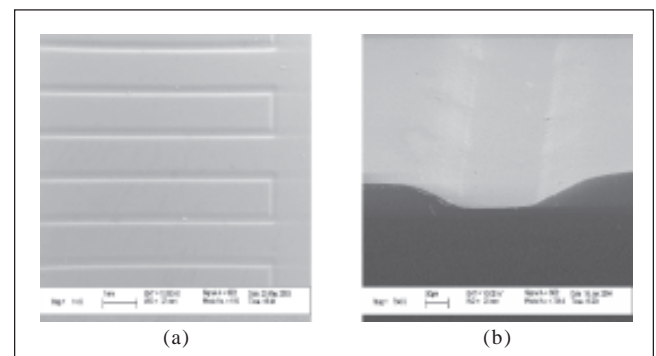

*Figure 5*

**SEM Pictures of Microchannel After HF Wet Etching:** (a) plane view, (b) section view

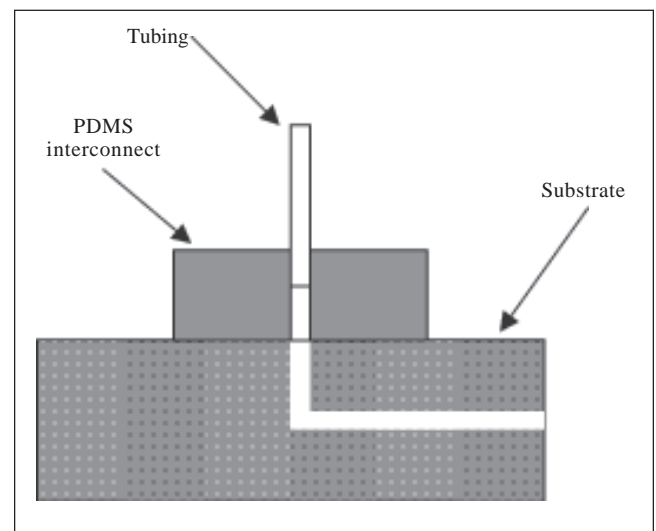

*Figure 6*

**Schematic of PDMS Interconnect**

microchannel. An infrared (IR) camera was used to measure the surface temperature distribution of the PCR device to verify the design. In this measurement, no DNA solution was inside the microchannel because the DNA solution effect is believed to be insignificant due to its small thermal mass.

Two PT100 thin-film temperature sensors (S245PD12, Minco, MN) were mounted on the Au-Cr microheaters using epoxy. These temperature sensors were used to provide feedback control of the thermal cycling. Two solid-state PID (proportional, integral, and derivative) controllers (CA16A2010-9502, Minco, MN) were used to control the reaction temperatures. The resolution of the PID controller is about  $0.1^{\circ}\text{C}$ . Two DC power supplies (EH382213, Davis Infotek Instruments, MD) provided power to the microheaters and PID controllers. *Figure 8* shows the configuration of the temperature control system.

The measured temperature distribution on the bottom surface of the glass chip was plotted in *Figure 9*. It is seen that a temperature zone ( $70^{\circ}\text{C} - 74^{\circ}\text{C}$ ) was established between the denaturation zone ( $95^{\circ}\text{C}$ ) and hybridization zone ( $55^{\circ}\text{C}$ ) on the two ends as a result of lateral heat conduction. Measured temperature uniformity was  $1.5^{\circ}\text{C}/\text{mm}$  for the denaturation zone,  $0.7^{\circ}\text{C}/\text{mm}$  for the hybridization zone, and  $3.1^{\circ}\text{C}/\text{mm}$  for the replication zone.

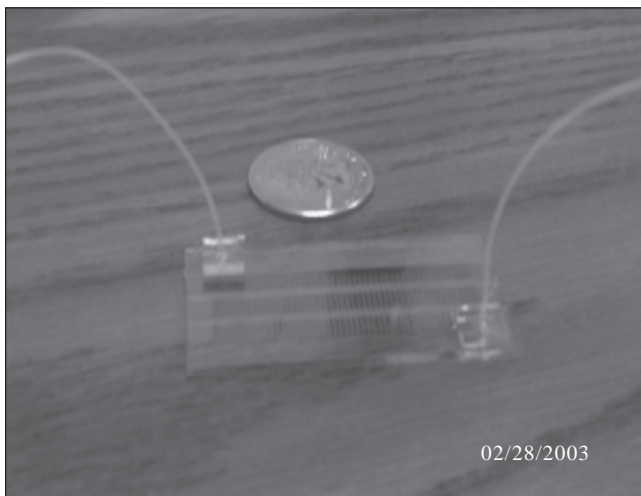

**Figure 7**  
Optical Micrograph of Integrated, Flow-Through DNA Chip Made of Glass with PDMS Interconnects

## Flow-Through Experiment

A  $50\ \mu\text{L}$  syringe (Hamilton Co., UK) was connected to a programmable syringe pump (Ne-1000, New Era Pump System, NY). The syringe pump was connected to the PCR chip using Teflon™ tubing (Hamilton Co., UK). The microchannel has a width of  $380\ \mu\text{m}$ , a depth of  $30\ \mu\text{m}$ , and a total length of approximately  $0.6\ \text{m}$ . Depending on the flow rate ( $5\ \text{nL/s}$  to  $80\ \text{nL/s}$ ), it takes only 52 seconds to 14 minutes for the 20-cycle chip to run through the sample.

## Conclusion

A continuous-flow, polymerase chain reaction (PCR) system was developed with integrated heaters and microfluidic interconnects made of polydimethylsiloxane (PDMS) material. This PDMS interconnect is biocompatible, easy to fabricate, and reliable to withstand pressures up to  $470\ \text{kPa}$ . This new PCR chip utilized the heat conduction mechanism to establish the replication temperature zone between the denaturation and hybridization zones at the two ends of the chip. This eliminated the thermal cross-talk problem in previous three-heater design while maintaining a reasonable temperature gradient across the PCR chip. The finite element method (FEM) was employed to analyze the temperature distribution in the DNA chip. The tempera-

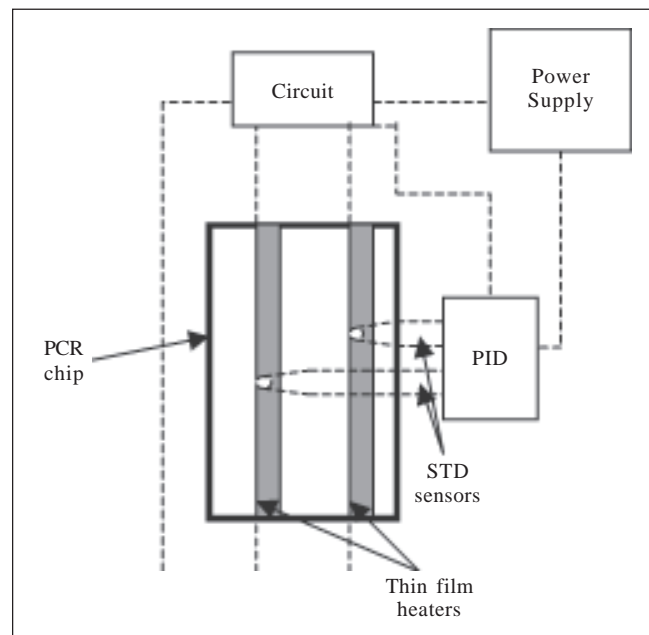

**Figure 8**  
Schematic Diagram of Temperature Control System

ture distribution shows good uniformity at each temperature zone. Several important micromanufacturing methods were developed in this work. These processes could be applied to develop other micro/mesoscale systems, which may apply to biomedical and life science applications.

### Acknowledgment

The authors appreciate facility support from the Microelectronics Research Center at the University of Texas at Austin. In particular, the authors thank Dr. Banerjee, Dr. Neikirk, and Dr. Ho for their equipment support. Financial support from the U.S. Dept. of Defense and a seed grant from the Biomedical Engineering Center at the Texas Medical Center

(funded in part by the Whitaker Foundation) are greatly appreciated.

### References

- Campbell, M.K. (1995). *Biochemistry*, 2nd ed. Saunders College Publishing.
- Kopp, M.U.; de Mello, A.J.; and Manz, A. (1998). "Chemical amplification: continuous-flow PCR on a chip." *Science* (v280), pp1046-1048.
- Lin, C.S.; Lee, G.B.; Lin, Y.H.; and Chang, G.L. (2001). "A fast prototyping process for fabrication of microfluidic systems on soda-lime glass." *Journal of Micromechanics and Microengineering* (v11), pp726-733.
- Lin, Y.C.; Huang, M.Y.; Young, K.C.; Chang, T.T.; and Wu, C.Y. (2000a). "A rapid micro-polymerase chain reaction system for hepatitis C virus amplification." *Sensors and Actuators B* (v71), pp2-8.
- Lin, Y.C.; Huang, M.Y.; Young, K.C.; Chang, T.T.; and Wu, C.Y. (2000b). "Simulation and experimental validation of micro polymerase chain reaction chip." *Sensors and Actuators B* (v71), pp127-133.
- Mullis, K.B.; Ferre, F.; and Gibbs, R.A. (1994). *The Polymerase Chain Reaction*. Boston: Birkhauser.
- Northup, M.A.; Bennett, B.; Hadley, D.; Landre, P.; Lehew, S.; and Stratton, P. (1998). "A miniature analytical instrument for nucleic acids based on micromachined silicon reaction chambers." *Analytical Chemistry* (v70), pp918-922.
- Obeid, P.J.; Chrisopoulos, T.K.; Crabtree, H.J.; and Backhouse, C.J. (2003). "Microfabricated device for DNA and RNA amplification by continuous-flow polymerase chain reaction and reverse transcription-polymerase chain reaction with cycle number selection." *Analytical Chemistry* (v75), pp288-295.
- Schneegab, I. and Kohler, J.M. (2001). "Flow through polymerase chain reaction in chip thermocyclers." *Reviews in Molecular Biotechnology* (v82), pp101-121.
- Sun, K.; Yamaguchi, A.; Ishida, Y.; Matsuo, S.; and Misawa, H. (2002). "A heater integrated transparent microchannel chip for continuous flow PCR." *Sensors and Actuators B* (v84), pp283-289.
- Zhang, Q.T.; Wang, W.H.; Zhang, H.S.; and Wang, Y.L. (2002). "Temperature analysis of continuous flow micro-PCR based on FEA." *Sensors and Actuators B* (v82), pp75-81.
- Zheng, W. and Chen, S.C. (2001). "Continuous flow, submicroliter scale PCR chip for DNA amplification." *Proc. of SPIE – the International Society for Optical Engineering* (v4560), pp256-262.
- Zheng, W. and Chen, S.C. (2002). "Continuous flow, nano-liter scale polymerase chain reaction system." *Transactions of NAMRI/SME* (v30), pp551-555.

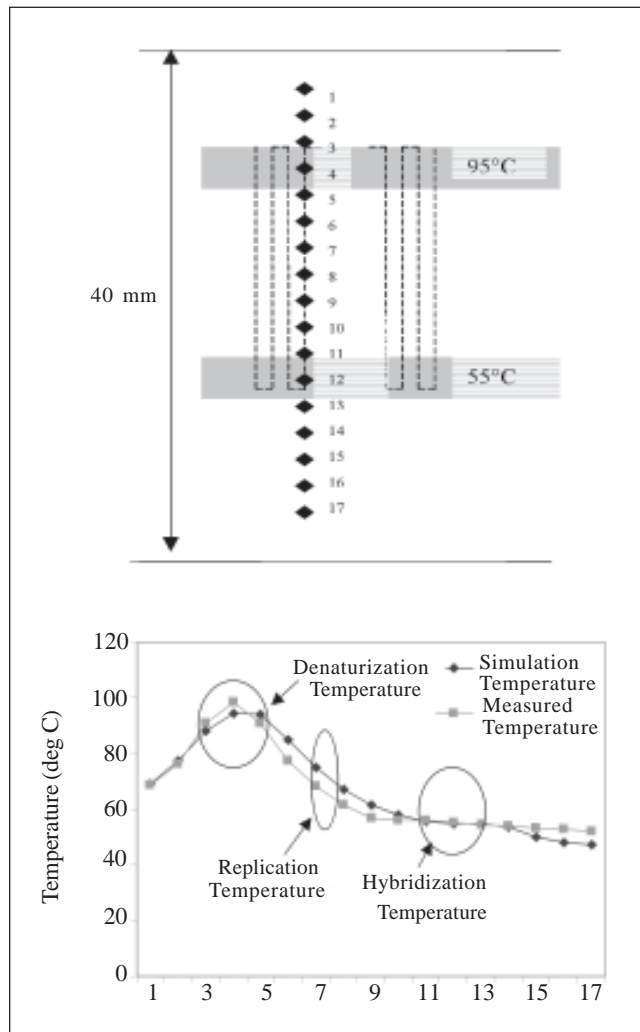

Figure 9  
 (a) Measuring points along the bottom glass surface,  
 (b) measured and simulated temperature distributions  
 on the glass surface of the PCR chip

### Authors' Biographies

Shifeng Li received the BS and MS degrees in mechanical engineering from Shanghai Jiaotong University, Shanghai, China, in 1994 and 1999, respectively, and is currently pursuing the PhD degree in the Mechanical Engineering Dept. at the University of Texas at Austin. His research focuses on design, fabrication, and simulation of microfluidic devices and BioMEMS.

Shaochen Chen received his PhD degree in mechanical engineering from the University of California-Berkeley in 1999. Currently, he is an assistant professor with in the Mechanical Engineering Dept. at the University of Texas at Austin. His research interests are in MEMS, laser materials processing, and thermal/fluid transport in micro/nanosystems. His research applications include biomedical engineering, microelectronics, and life science. Dr. Chen received the CAREER award from the U.S. National Science Foundation in 2001 and the Outstanding Young Manufacturing Engineer award from the Society of Manufacturing Engineers in 2002.